



atmosphere is everything

14716 S. Broadway • Gardena, CA 90248 • USA
 TEL: (310) 532-1555 • (800) 421-1266 • FAX: (310) 324-3030
 Web Site: www.marsair.com • E-mail: info@marsair.com

PROJECT		OPTIONS/ITEMS	
TITLE			
COMMENTS		DATE 4/10/15	PAGE
		REV. NO	
MODEL NO. WMI Series	DRAWING NO WMIU-F	DRAWN BY TVN	CHECKED BY
		FILE NAME	

Unheated Drawing

WMI (Wind Stopping 14) Series

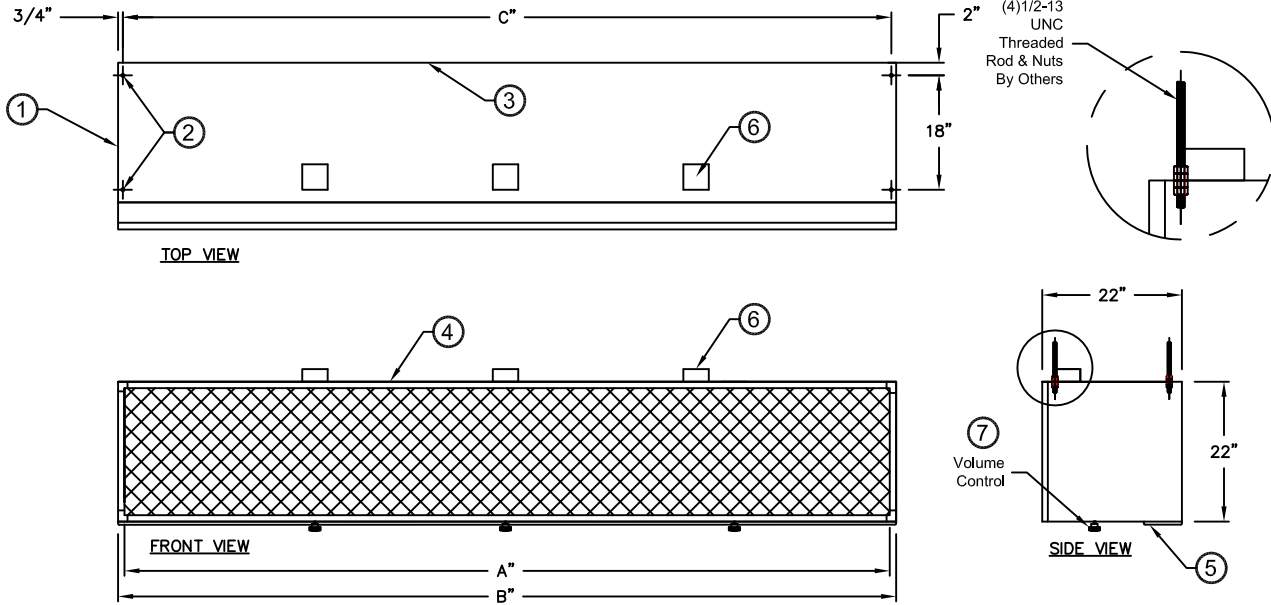

9 Recommended Accessories

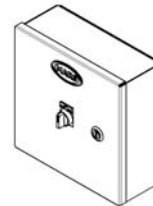

Control Panels

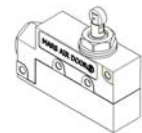

Door Limit Switches

*- Use corresponding letters in "Electrical Data" columns to complete the model numbers.

MODEL NUMBER	Nozzle Length (in)	Length (in)	Depth (in)
WMI96-2U*-TS	96	99	22
WMI120-2U*-TS	120	123	22
WMI144-2U*-TS	144	147	22
WMI168-3U*-TS	168	171	22
WMI192-4U*-TS	192	195	22

Notes:

- This product is designed to meet the National Electric Code (NEC) and is CSA Listed and AMCA 211 Certified.
- (4) 5/8" mounting holes provided on for overhead mounting provided, (2) on each end.
- All units have a self contained one piece cabinet, fire retardant and corrosion proof paint lock metal double protected with baked on Titanium Silver color, rust preventative electrostatic polyurethane powder coating.
- Cabinet is to be mounted from overhead and has sufficient strength for suspension from both ends without intermediate support.
- Unit is to be installed such that air flow is unobstructed. Unit has a 4.5" air discharge nozzle containing adjustable air directional vanes with 40° sweep front to back.
- Units are direct drive. One external top mounted 2"x4" J-box provided above each motor. VFD optional.
- Adjustable perforated volume dampers (2). Capable of reducing air velocity up to 50%.
- Circuit protection as per NEC by others.
- Optional motor control panel and door limit switch are field installed and/or wired by others. The door limit switch is to be mounted such that the air curtain turns on as door begins to open. To prevent unit damage, the air curtains must be installed such that the bottom of the air curtain is not below the door header.

WMI (Wind Stopping 14) Series

Unheated

Model Lengths 96" – 192"



atmosphere is everything

14716 S. BROADWAY, GARDENA, CA 90248 • Ph: (310)532-1555 Fax: (310)532-3030 • www.marsair.com
© Copyright Mars Air Systems, LLC 2014

Unheated Data Sheet

Applications: Environmental Separation-Interior Door up to 18' and Exterior Door up to 16'/Insect Control up to 14'

WMI (Wind Stopping 14)	Mechanical Data						Lab Data		AMCA Certified Lab Data			
Model Number	Nozzle Length (in)	Length (in)	Depth (in)	Height (in)	Motor (hp)	Weight (lbs)	Max Velocity (fpm)	Max Volume (cfm)	Avg Velocity (fpm)	Volume (cfm)	Uniformity (%)	Power Rating (watts)
WMI96-2U*-TS	96	99	22	22	Two 2	515	5500	16500	2614	7842	92	4260
WMI120-2U*-TS	120	123	22	22	Two 3	610	5200	19500	3205	9474	90	5600
WMI144-2U*-TS	144	147	22	22	Two 3	695	5800	26100	3009	13422	86	6340
WMI168-3U*-TS	168	171	22	22	Three 3	880	4900	25725	2920	15060	84	8070
WMI192-4U*-TS	192	195	22	22	Four 2	1030	5500	33000	2614	15684	92	8520

* - Use corresponding letters in "Electrical Data" columns to complete the model numbers

Features:

- ❖ 2 to 3 HP continuous duty industrial motors
- ❖ Direct drive unit for heavy duty industrial projects
- ❖ AMCA Certified units (see table above for models available)
- ❖ CSA Certified to conform to UL 507 (US) and CSA 22.2 (Canada) Standards
- ❖ Top and wall mounting holes provided (5/8")
- ❖ Cabinet has sufficient strength for fastening to wall on both ends without intermediate support.
- ❖ Adjustable air directional vanes with 40° sweep front to back
- ❖ Standard color is Titanium Silver
- ❖ Rust preventative electrostatic polyurethane powder coating
- ❖ 18 month parts warranty
- ❖ Freight Not Included (FOB Factory)
- ❖ Proudly Made in the USA

Electrical Data (FLA)	Unit Voltage (Voltage Code)		
	208/230v (G)	460v (H)	575v (I)
WMI96-2U*-TS	14.4/14.0	7.0	4.6
WMI120-2U*-TS	28.4/21.2	10.6	4.6
WMI144-2U*-TS	28.4/21.2	10.6	4.6
WMI168-3U*-TS	42.6/31.8	15.9	6.9
WMI192-4U*-TS	28.8/28.0	14.0	9.2

* - Use corresponding letters in "Electrical Data" columns to complete the model numbers.

Note: For Ampacity Multiply FLA X 1.25

Options and Accessories: (see Accessories Brochure)

- ❖ Motor Control Panels
- ❖ Washdown units and accessories (NEMA 4x)
- ❖ Explosion Resistant units and accessories (Class I, Div. I, Group D)
- ❖ Custom colors and finishes (304SS & 316SS)

Sound Levels: (measured at 10' in an open field)

2 Motor Unit = 66 dBA, 3 Motor Unit = 67 dBA & 4 Motor Unit = 68 dBA

EXAMPLE

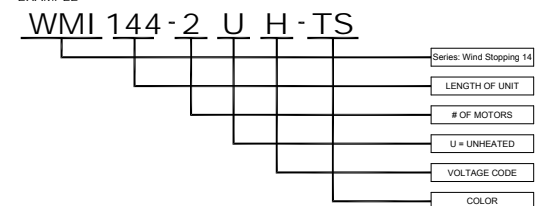

Model	Projection Velocity	
	Distance from nozzle (in)	Avg. Core Velocity (FPM)
WMI60-1U*-TS	36"	2180
	84"	1493
	132"	1240



MARS Air Systems, LLC certifies that the Air Curtains shown on this data sheet are licensed to bear the AMCA seal. The rating shown are based on tests and procedures performed in accordance with AMCA Publication 211 and comply with the requirements of the AMCA Certified Ratings Program.



NOTE: MARS AIR SYSTEMS, LLC reserves the right to change specifications and product design without notice. Such revisions do not entitle the buyer to corresponding changes, improvements, additions or replacements for previously purchased equipment.