



atmosphere is everything

14716 S. Broadway • Gardena, CA 90248 • USA
 TEL: (310) 532-1555 • (800) 421-1266 • FAX: (310) 324-3030
 Web Site: www.marsair.com • E-mail: info@marsair.com

PROJECT		OPTIONS/ITEMS	
TITLE			
COMMENTS		DATE 7/20/15	PAGE
		REV. NO	
MODEL NO. WMI Series	DRAWING NO. WMIU-F	DRAWN BY NT	CHECKED BY
		FILE NAME	

Hot Water/Steam Heated Drawing

WMI (Wind Stopping 14) Series

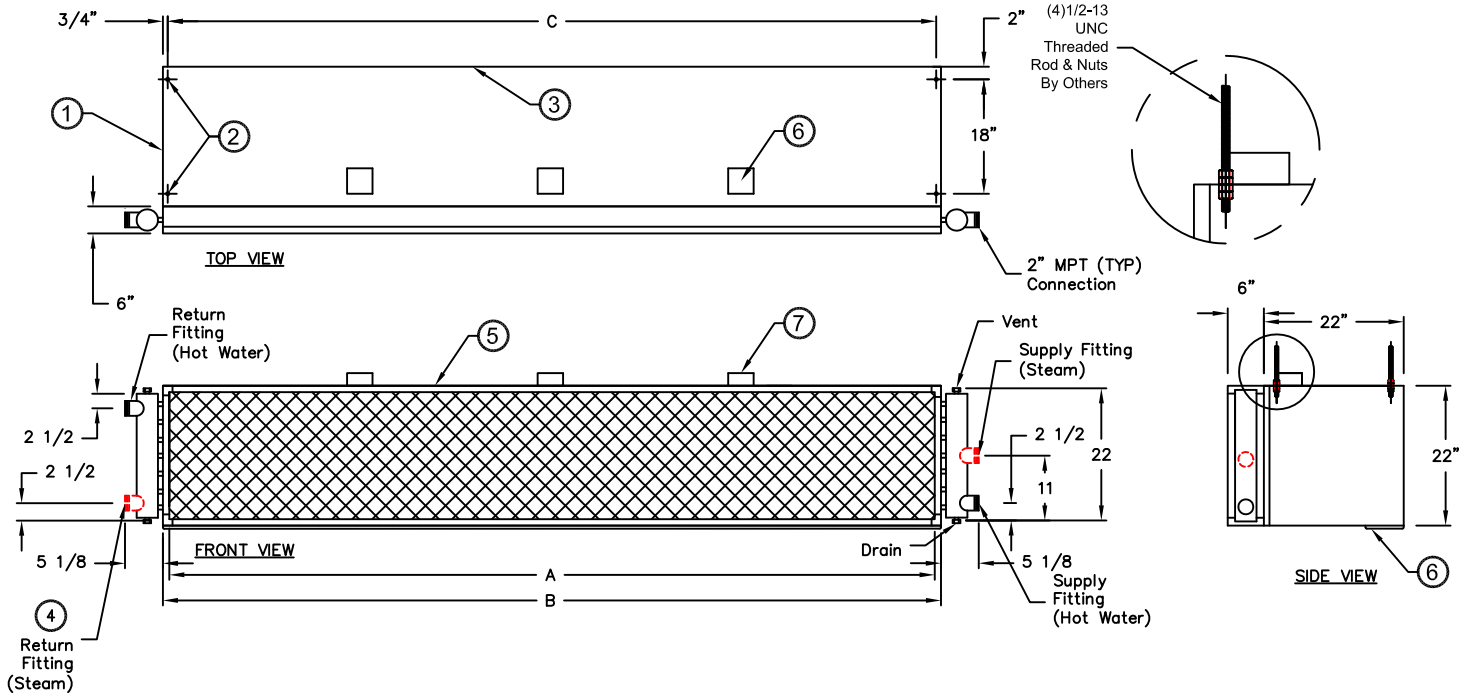

9 Recommended Accessories

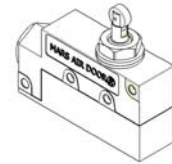

Control Panels with Remote T'stat

Door Limit Switches

*- Use corresponding letters in "Coil Data" and "Electrical Data" columns to complete the model numbers.

MODEL NUMBER	NOZZLE LENGTH A (in)	OVERALL LENGTH B (in)	MOUNTING CENTER C (in)
WMI96-2**-TS	96	99	97 1/2
WMI120-2**-TS	120	123	121 1/2
WMI144-2**-TS	144	147	145 1/2
WMI168-3**-TS	168	171	169 1/2
WMI192-4**-TS	192	195	193 1/2

Notes:

- This product is designed to meet the National Electric Code (NEC) and is CSA Listed
- (4) 5/8" mounting holes provided on for overhead mounting provided, (2) on each end.
- All units have a self contained one piece cabinet, fire retardant and corrosion proof paint lock metal double protected with baked on Titanium Silver color, rust preventative electrostatic polyurethane powder coating.
- Hot Water application shown. For Steam, return fitting is at the bottom of manifold and supply is at center of manifold. (2" MPT Typical)
- Cabinet is to be mounted from overhead and has sufficient strength for suspension from both ends without intermediate support.
- Unit is to be installed such that air flow is unobstructed. Unit has a 4.5" air discharge nozzle containing adjustable air directional vanes with 40° sweep front to back.
- Units are direct drive. One external top mounted 2"x4" J-box provided above each motor. VFD optional.
- Circuit protection as per NEC by others.
- Optional motor control panel and door limit switch are field installed and/or wired by others. The door limit switch is to be mounted such that the air curtain turns on as door begins to open. To prevent unit damage, the air curtain must be installed such that the bottom of the air curtain is not below the door header.

WMI (Wind Stopping) Series

Hot Water/Steam Heated

Model Lengths 96" – 192"



atmosphere is everything

14716 S. BROADWAY, GARDENA, CA 90248 • Ph: (310) 532-1555 Fax: (310) 532-3030 • www.marsair.com
© Copyright Mars Air Systems, LLC 2014

Hot Water/Steam Heated Data Sheet

Applications: Environmental Separation - Interior Door up to 18' and Exterior Door up to 16'

WMI (Wind Stopping 14)	Mechanical Data						Lab Data					
Model Number	Nozzle Length (in)	Length (in)	Depth (in)	Height (in)	Motor (hp)	Weight (lbs)	Max Velocity (fpm)	Max Volume (cfm)	Avg Velocity (fpm)	Volume (cfm)	Uniformity (%)	Power Rating (watts)
WMI96-2**-TS	96	99	30	22	Two 2	630	5500	16500	2614	7842	92	4260
WMI120-2**-TS	120	123	30	22	Two 3	755	5200	19500	3205	9474	90	5600
WMI144-2**-TS	144	147	30	22	Two 3	865	5800	26100	3009	13422	86	6340
WMI168-3**-TS	168	171	30	22	Three 3	1080	4900	25725	2920	15060	84	8070
WMI192-4**-TS	192	195	30	22	Four 2	1260	5500	33000	2614	15684	92	8520

* - Use corresponding letters in "Coil Data" then "Electrical Data" columns to complete the model numbers.

Features:

Air Curtain

- ❖ 2 to 3 HP Continuous Duty Motors (TEAO)
- ❖ ETL Certified to conform to UL 1995 (US) and CSA 22.2 (Canada) Standards
- ❖ Cabinet with sufficient strength for fastening from overhead on both ends without intermediate support. Top mounting holes provided (4) 5/8"
- ❖ Adjustable air directional vanes with 40° sweep front to back
- ❖ Standard color is Titanium Silver
- ❖ Rust preventative electrostatic polyurethane powder coating
- ❖ All units are shipped fully assembled ready for installation
- ❖ 18 months parts warranty
- ❖ Freight Not Included (FOB Factory)
- ❖ Proudly Made in the USA

Hot Water and Steam Coils

- ❖ Coil casings shall not be less than 16 gauge galvanized steel with tube holes formed with extruded collars.
- ❖ Fins are die formed .006" aluminum (1 row – 10 FPI, 2 row – 8 FPI)
- ❖ Coils tubes constructed of heavy wall, 5/8" OD seamless copper (Steam - .035" & Hot Water - .025")
- ❖ Coil tubes arranged in a staggered pattern and mechanically expanded into fins to ensure a uniform pressure bond
- ❖ Manifolds shall be of heavy seamless copper construction
- ❖ All joints shall be brazed with high temperature silver brazing alloy (Steam – 7% & Hot Water – 3%), max steam operating pressure: 30 PSI
- ❖ Fittings shall be of wrought copper or similar construction such that the entire fluid circuit shall be of compatible nonferrous materials.
- ❖ Manifold shall be fitted with 1/4" vent or drain fittings
- ❖ Supply fitting is on the right side of coil. Return fitting is on the left side

Options and Accessories: (see Accessories Brochure)

- ❖ Motor Control Panels with remote mounted t'stat
- ❖ Steam distribution, Cupro Nickel and CRN coils
- ❖ Rust resistant epoxy coated or SS coils
- ❖ Custom housing and transition colors and finishes (304SS, 316SS, Aluminum)

Sound Levels: (measured at 10' in an open field)

1 Motor Unit = 70 dBA, 2 Motor Unit = 73 dBA, 3 & 4 Motor Unit = 75 dBA

Coil Data	Hot Water				Steam		
	Coil Code (X)	GPM	MBH	Temp Rise (°F)	Coil Code (Y)	MBH	Temp Rise (°F)
WMI96-2**-TS	2 Row	12	299	35	1 Row	324	38
WMI120-2**-TS	2 Row	13	361	35	1 Row	399	39
WMI144-2**-TS	2 Row	20	502	35	1 Row	523	36
WMI168-3**-TS	2 Row	20	560	35	1 Row	599	37
WMI192-4**-TS	2 Row	19	590	35	1 Row	652	39

EAT: 70 F, EWT: 200 F, Steam pressure: 5 PSI

Electrical Data (FLA)	Unit Voltage (Voltage Code)		
	208/230v/3Ø (G)	460v/3Ø (H)	575v/3Ø (I)
WMI96-2**-TS	14.4/14.0	7.8	4.6
WMI120-2**-TS	28.4/21.2	11.8	4.6
WMI144-2**-TS	28.4/21.2	11.8	4.6
WMI168-3**-TS	42.6/31.8	17.7	6.9
WMI192-4**-TS	28.8/28.0	15.6	9.2

* - Use corresponding letters in "Electrical Data" columns to complete the model numbers.

Note: For Ampacity Multiply FLA X 1.25

EXAMPLE

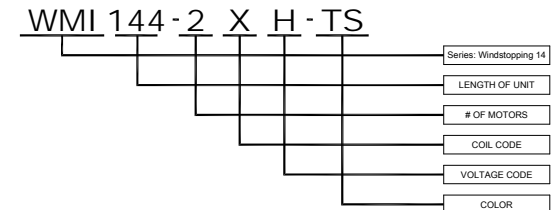

NOTE: MARS AIR SYSTEMS, LLC reserves the right to change specifications and product design without notice. Such revisions do not entitle the buyer to corresponding changes, improvements, additions or replacements for previously purchased equipment.