



atmosphere is everything

14716 S. Broadway • Gardena, CA 90248 • USA  
 TEL: (310) 532-1555 • (800) 421-1266 • FAX: (310) 324-3030  
 Web Site: www.marsair.com • E-mail: info@marsair.com

PROJECT		OPTIONS/ITEMS	
TITLE		DATE	
COMMENTS		4/14/15	PAGE
		REV. NO	
MODEL NO. WMH Series	DRAWING NO WMHU-F	DRAWN BY TVN	CHECKED BY
		FILE NAME	

## Unheated Drawing

### WMH (Wind Stopping 16) Series

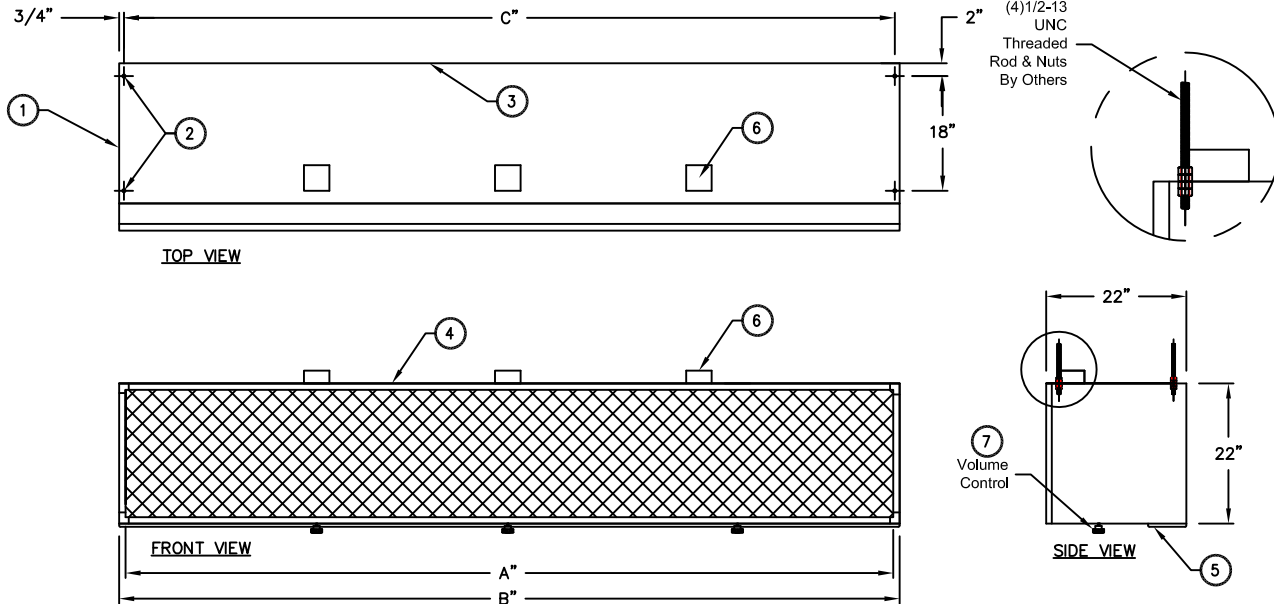

### 9 Recommended Accessories



Control Panels

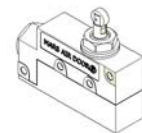

Door Limit Switches

\*- Use corresponding letters in "Electrical Data" columns to complete the model numbers.

MODEL NUMBER	Nozzle Length (In)	Length (In)	Depth (In)
WMH96-2U*-TS	96	99	22
WMH120-2U*-TS	120	123	22
WMH144-2U*-TS	144	147	22
WMH168-3U*-TS	168	171	22
WMH192-4U*-TS	192	195	22

#### Notes:

- This product is designed to meet the National Electric Code (NEC), CSA Listed and is AMCA 211 Certified.
- (4) 5/8" mounting holes provided on for overhead mounting provided, (2) on each end.
- All units have a self contained one piece cabinet, fire retardant and corrosion proof paint lock metal double protected with baked on Titanium Silver color, rust preventative electrostatic polyurethane powder coating.
- Cabinet is to be mounted from overhead and has sufficient strength for suspension from both ends without intermediate support.
- Unit is to be installed such that air flow is unobstructed. Unit has a 4.5" air discharge nozzle containing adjustable air directional vanes with 40° sweep front to back.
- Units are direct drive. One external top mounted 2"x4" J-box provided above each motor. VFD optional.
- Adjustable perforated volume dampers (2). Capable of reducing air velocity up to 50%.
- Circuit protection as per NEC by others.
- Optional motor control panel and door limit switch are field installed and/or wired by others. The door limit switch is to be mounted such that the air curtain turns on as door begins to open. To prevent unit damage, the air curtain must be installed such that the bottom of the air curtain is not below the door header.

# WMH (Wind Stopping 16) Series

Unheated

Model Lengths 96" – 192"



atmosphere is everything

14716 S. BROADWAY, GARDENA, CA 90248 • Ph: (310)532-1555 Fax: (310)-532-3030 • [www.marsair.com](http://www.marsair.com)  
© Copyright Mars Air Systems, LLC 2014

## Unheated Data Sheet

**Applications: Environmental Separation-Interior Door up to 20' and Exterior Door up to 18'/Insect Control up to 16'**

WMH (Wind Stopping 16)	Mechanical Data						Lab Data		AMCA Certified Lab Data			
Model Number	Nozzle Length (in)	Length (in)	Depth (in)	Height (in)	Motor (hp)	Weight (lbs)	Max Velocity (fpm)	Max Volume (cfm)	Avg Velocity (fpm)	Volume (cfm)	Uniformity (%)	Power Rating (watts)
WMH96-2U*-TS	96	99	22	22	Two 5	635	7300	21900	4466	13190	91	9390
WMH120-2U*-TS	120	123	22	22	Two 5	735	7600	28500	4231	15670	89	12420
WMH144-2U*-TS	144	147	22	22	Two 7	890	7400	33300	3816	17022	82	13300
WMH168-3U*-TS	168	171	22	22	Three 5	1060	6700	35175	3822	19845	90	17700
WMH192-4U*-TS	192	195	22	22	Four 5	1275	7300	43800	4466	26380	91	18760

\* - Use corresponding letters in "Electrical Data" columns to complete the model numbers.

### Features:

- ❖ 5 & 7 HP continuous duty industrial motors
- ❖ Direct drive unit for heavy duty industrial projects
- ❖ AMCA Certified units (see table above for models available)
- ❖ CSA Certified to conform to UL 507 (US) and CSA 22.2 (Canada) Standards
- ❖ Top and wall mounting holes provided (5/8")
- ❖ Cabinet has sufficient strength for fastening to wall on both ends without intermediate support.
- ❖ Adjustable air directional vanes with 40° sweep front to back
- ❖ Standard color is Titanium Silver
- ❖ Rust preventative electrostatic polyurethane powder coating
- ❖ 18 month parts warranty
- ❖ Freight Not Included (FOB Factory)
- ❖ Proudly Made in the USA

### Options and Accessories: (see Accessories Brochure)

- ❖ Motor Control Panels
- ❖ Washdown units and accessories (NEMA 4x)
- ❖ Explosion Resistant units and accessories (Class I, Div. I, Group D)
- ❖ Custom colors and finishes (304SS & 316SS)

### Sound Levels: (measured at 10' in an open field)

2 Motor Unit = 69 dBA, 3 Motor Unit = 70 dBA & 4 Motor Unit = 72 dBA

Electrical Data (FLA)	Unit Voltage (Voltage Code)		
	208/230v (G)	460v (H)	575v (I)
WMH96-2U*-TS	38/31.6	15.8	12.6
WMH120-2U*-TS	38/31.6	15.8	12.6
WMH144-2U*-TS	--/42.0	21.0	16.8
WMH168-3U*-TS	57/47.4	23.7	18.9
WMH192-4U*-TS	76/63.2	31.6	25.2

\* - Use corresponding letters in "Electrical Data" columns to complete the model numbers

Note: For Ampacity Multiply FLA X 1.25

Model	Projection Velocity	
	Distance from nozzle (in)	Avg. Core Velocity (FPM)
WMH60-1U*-TS	36"	3979
	84"	2243
	132"	1878



MARS Air Systems, LLC certifies that the Air Curtains shown on this data sheet are licensed to bear the AMCA seal. The rating shown are based on tests and procedures performed in accordance with AMCA Publication 211 and comply with the requirements of the AMCA Certified Ratings Program.



EXAMPLE

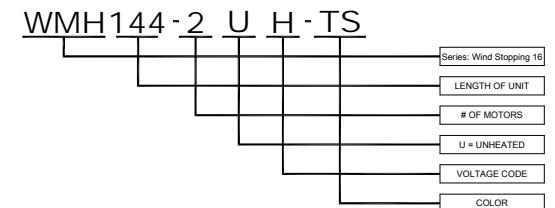

NOTE: MARS AIR SYSTEMS, LLC reserves the right to change specifications and product design without notice. Such revisions do not entitle the buyer to corresponding changes, improvements, additions or replacements for previously purchased equipment.