

Vibration Isolation

For All Models



atmosphere is everything

14716 S. BROADWAY, GARDENA, CA 90248 • Ph: (310)532-1555 Fax: (310)-532-3030 • www.marsair.com
© Copyright Mars Air Systems, LLC 2014

Vibration Isolation

Features:

- ❖ Spring elements and brackets are powder coated
- ❖ Load plates are bright zinc plated
- ❖ Isolation hangers have a typical overload of 50%
- ❖ Isolation hangers have a minimum spring stability k_x/k_y ratio of 1.0
- ❖ Spring elements are safe at solid loading without it yielding and taking a permanent set, even with small amplitudes of excitation around overload conditions
- ❖ Hanger brackets will carry (5) times overload without failure
- ❖ Hanger brackets will allow 30° rod misalignment from isolated portion to fixed portion without short circuiting
- ❖ Isolation hangers marked K050* include a neoprene cup at the bottom of the spring coil, fitted to prevent the metal to metal contact. Larger diameter coils are provided with larger clearance holes in the bracket which ensures a proper air gap
- ❖ Patented "No Short" step cap component are used to ensure the lower (isolated) hanger rod remains centered on the isolator coil. Smaller diameter rods may be fitted with a washer on concentric depressions which automatically centers the hanger rod on the coil, regardless of hanger rod diameter.
- ❖ Vibration isolation used only for overhead mounting
- ❖ Vibration isolation hangers and spring elements are field assembled and installed
- ❖ 1 year warranty
- ❖ Freight not included
- ❖ Proudly Made in the USA

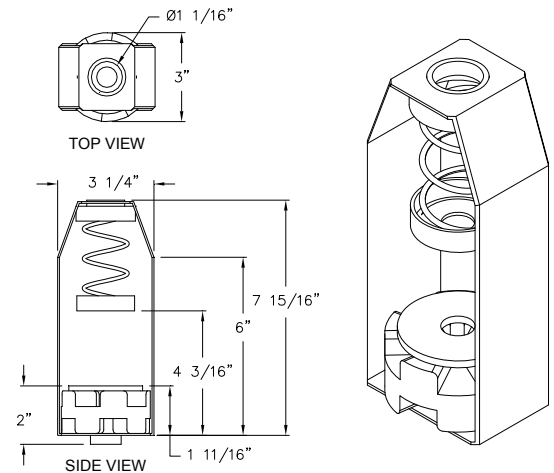

Options and Accessories: (see Accessories Brochure)

- ❖ Custom Vibration Isolation enclosures available (Obsidian Black, Titanium Silver, 304 SS)
- ❖ Factory mounting available (contact factory)

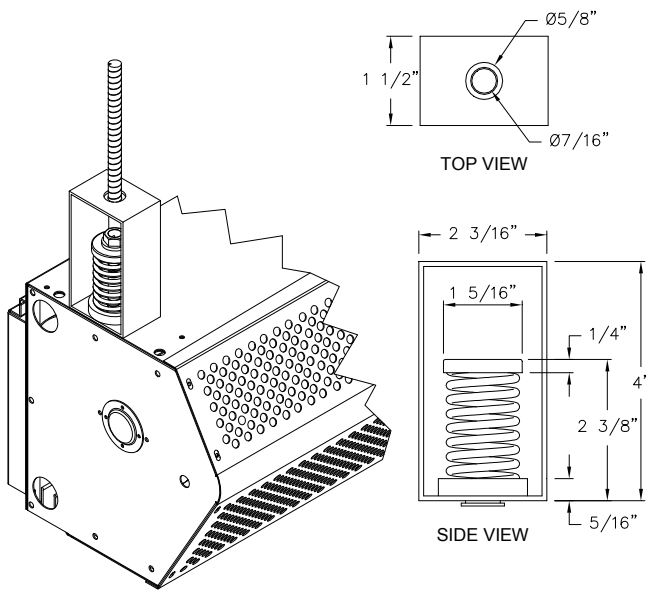

Commercial Spring Assembly

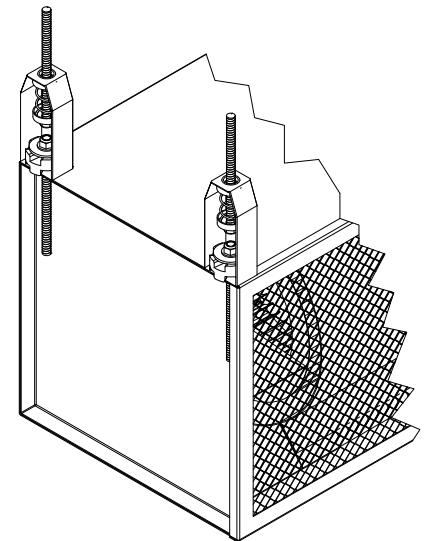
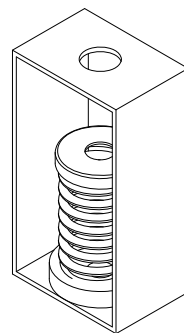

Industrial Spring Assembly

NOTE: MARS AIR SYSTEMS, LLC reserves the right to change specifications and product design without notice. Such revisions do not entitle the buyer to corresponding changes, improvements, additions or replacements for previously purchased equipment.

Vibration Isolation

For All Models



atmosphere is everything

14716 S. BROADWAY, GARDENA, CA 90248 • Ph: (310)532-1555 Fax: (310)-532-3030 • www.marsair.com
© Copyright Mars Air Systems, LLC 2014

Vibration Isolation Selection Guide

Air Curtain Series	Unheated Air Curtain Length (in)	Electric Heated Air Curtain Length (in)	HWS Heated Air Curtain Length (in)	Vibration Isolation Model #
LPV2/LPN2 (LoPro 2 & Sanitation Series)	25 & 36	-	-	K0101
	-	-	25, 36, 42, 48, 60, 72	K0102
	-	-	84 & 96	K0103
	42, 48, 60, 72	25, 36, 42, 48, 60, 72	-	K0104
	84, 96, 108, 120	84, 96, 108, 120	108, 120, 144	K0105
	144	144	-	K0108
STD2/N2 (Standard 2 & Sanitation Series)	36, 42, 48, 60-1	-	36	K0102
	60-2 & 64-2	36, 42, 48	42, 48, 60-1	K0105
	72, 84, 96, 108, 120, 144	60, 64, 72, 78, 84, 96	60-2, 72, 78	K0108
	-	108-144	96-2, 108, 120-2	K0112
	-	-	84 & 96-2	K0110
	-	-	120-3 & 144	K0501
HV2/NH2 (High Velocity 2 & Sanitation Series)	36	-	-	K0102
	42, 48, 60	36	-	K0105
	72, 84, 96	42, 48, 60	36, 42, 48, 60	K0108
	108, 120, 144	96, 120-2	72, 84, 96-2	K0112
	-	72 & 84	-	K0110
	-	120-3 & 144	96-3, 108, 120, 144	K0501
EP2 (Extra Power 2 Series)	36, 42, 48	-	-	K0105
	60 & 72	36, 42, 48, 60	36, 42, 48, 60	K0108
	108-3, 120, 144-3	72, 84, 96, 108-2	72, 84, 96-2	K0112
	84, 96, 108-2	108-3, 120, 144	-	K0110
	144-4	-	96-3, 108, 120, 144	K0501
PH10 (Phantom 10 Series)	36, 42, 48, 60-1	36, 42, 48	-	K0105
	60-2, 64, 72	60 & 72	36, 42, 48, 60, 72	K0108
	84, 96, 108, 120, 144	84, 96, 108, 120, 144-3	84, 96, 108, 120	K0109
	-	144-4	144	K0111
PH12 (Phantom 12 Series)	36	36	36, 42, 48, 60-1	K0105
	42, 48, 60, 64, 72	42, 48, 60, 64, 72	-	K0108
	84, 96, 108, 120, 144	84, 96, 108, 120, 144	84, 96, 108, 120	K0109
	-	-	60-2, 72	K0110
	-	-	144	K0111
WMI (Wind Stopping 14 Series)	96	-	-	K0501
	108, 120, 144, 168	96, 108, 120, 144	96, 108, 120	K0502
	180 & 192	168, 180, 192	144, 168, 180, 192	K0503
WMH (Wind Stopping 16 Series)	96	-	-	K0501
	108, 120, 144, 168	96, 108, 120	96, 108, 120	K0502
	180 & 192	144, 168, 180, 192	144, 168, 180, 192	K0503
BD14 (Belt Drive 14 Series)	96	-	-	K0501
	120, 144, 168, 180, 192	96, 120, 144	96 & 120	K0502
	-	168 & 192	144, 168, 192	K0503
BD18 (Belt Drive 18 Series)	96	-	-	K0501
	120, 144, 168, 180, 192	96, 120, 144	96	K0502
	-	168 & 192	120, 144, 168, 180, 192	K0503
BD22 (Belt Drive 22 Series)	96, 120, 144, 168	96 & 120	96	K0502
	192	144, 168, 192	120, 144, 168, 180, 192	K0503
BD26 (Belt Drive 26 Series)	96, 120, 144, 168	96 & 120	-	K0502
	192	144, 168, 192	96, 120, 144, 168, 192	K0503
BD30 (Belt Drive 30 Series)	96, 120, 144	96 & 120	-	K0502
	168 & 192	144, 168, 192	96, 120, 144, 168, 192	K0503

NOTE: MARS AIR SYSTEMS, LLC reserves the right to change specifications and product design without notice. Such revisions do not entitle the buyer to corresponding changes, improvements, additions or replacements for previously purchased equipment.