

NOZZLE EXTENSION ASSY  
ISOMETRIC VIEW

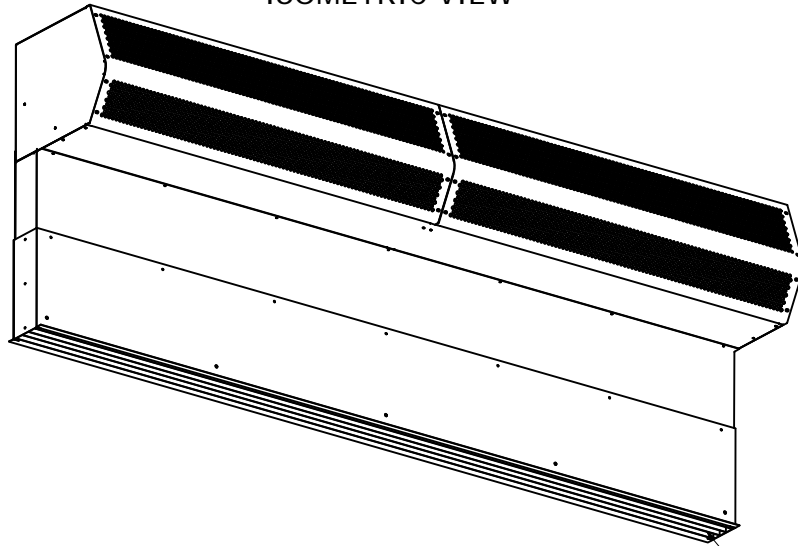

NOZZLE VANES  
(3" DEPTH)

EXPLODED VIEW

STD2, HV2, EP2 SERIES

NOZZLE EXTENSION ASSY.  
(8" HEIGHT)

DUCT EXTENSION ASSY.  
(9" HEIGHT)  
SCREW TO NOZZLE EXTENSION  
AT DESIRED HEIGHT

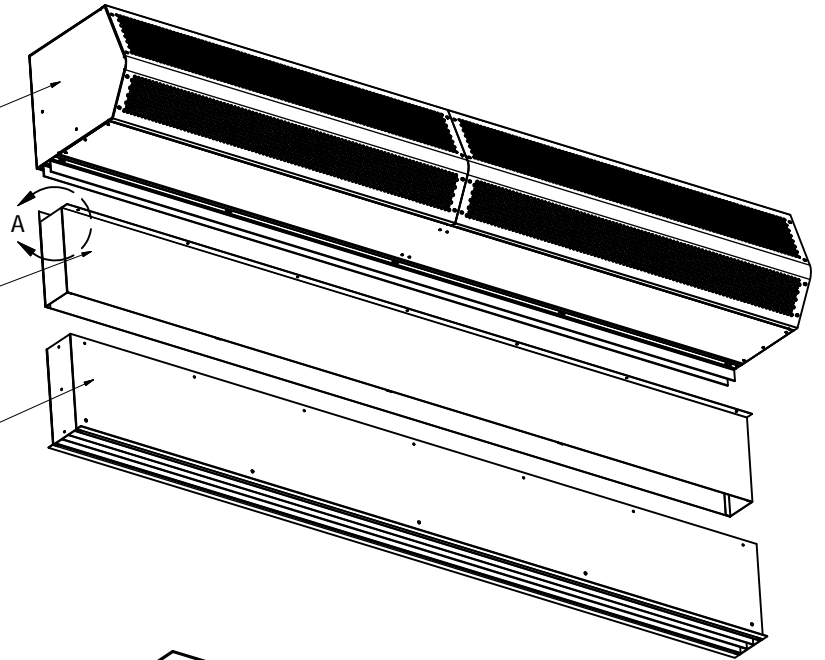

SCREW NOZZLE EXTENSION FLANGE  
TO AIR CURTAIN FROM BACK

SCREW NOZZLE EXTENSION FLANGE  
TO AIR CURTAIN FROM BOTTOM

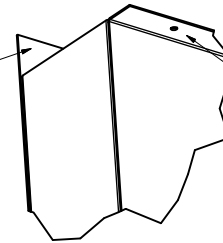

DETAIL A  
SCALE .5

EXTENSION RANGE : 9.5" TO 16" WITH DUCT EXTENSION

: 8" WITHOUT DUCT EXTENSION.

(VANES NEED TO BE MOUNTED TO THE NOZZLE AND SEPERATE TRIM KIT NEEDED)

NOTE: FOR UNITS LONGER THAN 72", USE TWO NOZZLE EXTENSION ASSY. OF SAME SIZE  
EXCEPT 78" AND 108" (EXAMPLE - 120" UNIT WILL USE TWO 60" NOZZLE EXTENSION ASSY.)

FOR 78" UNIT, USE 36" AND 42" NOZZLE EXTENSION ASSY.

FOR 108" UNIT, USE 60" AND 48" NOZZLE EXTENSION ASSY.

*THERE WILL BE 10% REDUCTION IN PROJECTION VELOCITY WITH THE USE OF NOZZLE EXTENSION.*



atmosphere is everything