



atmosphere is everything

14716 S. Broadway • Gardena, CA 90248 • USA
 TEL: (310) 532-1555 • (800) 421-1266 • FAX: (310) 324-3030
 Web Site: www.marsair.com • E-mail: info@marsair.com

PROJECT		OPTIONS/ITEMS	
TITLE			
COMMENTS		DATE 4/17/15	PAGE
		REV. NO	
MODEL NO. PH10 Series	DRAWING NO PH10ELC-F	DRAWN BY TVN	CHECKED BY
		FILE NAME	

Electric Heated Drawing

PH10 (Phantom 10 Series)

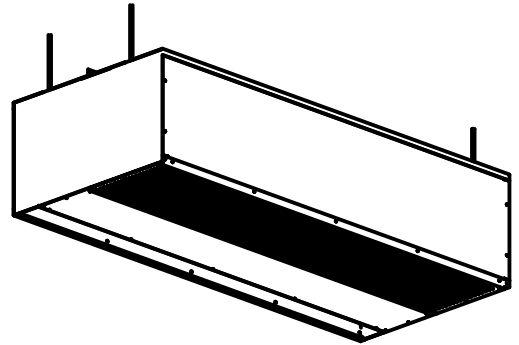
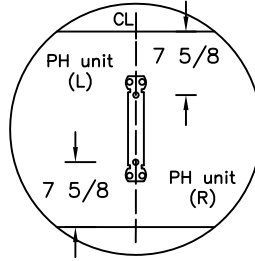
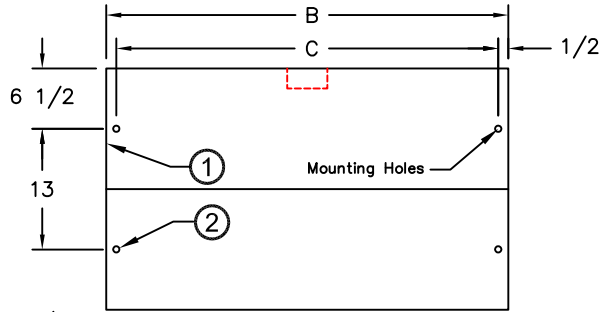

For tandem mounted units, center support required. The (2) center mounting holes are centerline of unit and 7 5/8" from front and rear of unit.

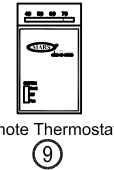
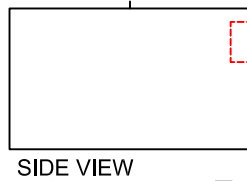
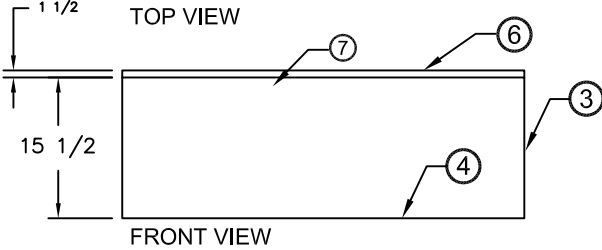

Recommended Accessories (11)

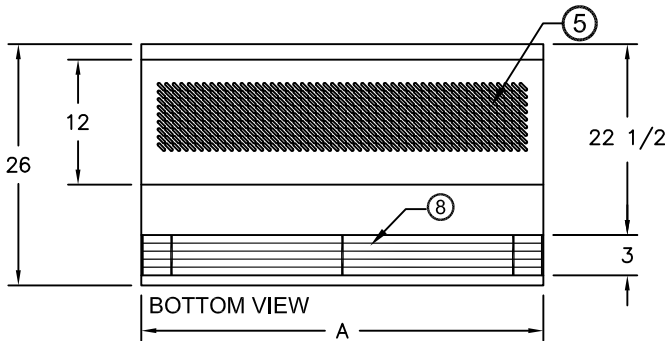

*- Use corresponding letters in "Voltage Code" then "Wattage Code" columns to complete the model numbers.

Note: MARS reserves the right to change specifications and product design without notice. Such revisions do not entitle the buyer to corresponding changes, improvements additions or replacements for previously purchased equipment.

Notes:

- This product is designed to meet the National Electric Code (NEC) and is ETL listed for the US and Canada (UL 1995 and CSA 22.2).
- (4) 3/8" threaded rod required for overhead installation.
- All units have a self contained one piece cabinet, fire retardant with brushed aluminum housing. The exposed bottom surface is protected with baked on Pearl White color, rust preventative electrostatic polyurethane powder coating.
- Pearl White trim pieces included to match air curtains and ceilings.
- Cleanable polyester filters included as standard. Optional aluminum or throwaway pleated filters available.
- Cabinet has sufficient strength for fastening to wall on both ends without intermediate support. Tandem mounted units longer than 72" require center support.
- Control panel is pre-wired and pre-mounted inside the cabinet. Optional remote mounted available.
- Unit is to be installed such that air flow is unobstructed. Unit has a 3" air discharge nozzle containing adjustable air directional vanes with 40° sweep front to back.
- Wall mounted 24 volt thermostat with remote "heat/off/fan" switch is shipped loose and field installed by others. Terminal block provided inside control panel.
- Circuit protection as per NEC by others.
- Optional remote control panel, door limit switch and mounting brackets are field installed and/or wired by others. The door limit switch is to be mounted such that the air curtain turns on as door begins to open. To prevent unit damage, the mounting brackets must be installed such that the bottom of the air curtain is not below the door header.

MODEL NUMBER	NOZZLE WIDTH A (in)	OVERALL LENGTH B (in)	MOUNTING CENTER C (in)
PH1036-1E**-PW	36	36 1/8	35 1/8
PH1042-1E**-PW	42	42 1/8	41 1/8
PH1048-1E**-PW	48	48 1/8	47 1/8
PH1060-2E**-PW	60	60 1/8	59 1/8
PH1072-2E**-PW	72	72 1/8	71 1/8
PH1084-2E**-PW	84	84 1/4	83 1/4
PH1096-2E**-PW	96	96 1/4	95 1/4
PH10108-3E**-PW	108	108 1/4	107 1/4
PH10120-4E**-PW	120	120 1/4	119 1/4
PH10144-4E**-PW	144	144 1/4	143 1/4

PH10 (Phantom 10) Series

Electric Heated

Model Lengths 36" – 144"



atmosphere is everything

14716 S. BROADWAY, GARDENA, CA 90248 • Ph: (310)532-1555 Fax: (310)532-3030 • www.marsair.com
© Copyright Mars Air Systems, LLC 2014

Electric Heated Data Sheet

Applications: Environmental Separation (up to 10')

PH10 (Phantom 10) Model Number	Mechanical Data						Lab Data					
	Nozzle Length (in)	Length (in)	Depth (in)	Height (in)	Motor (hp)	Weight (lbs)	Max Core Velocity at Nozzle (fpm)	Avg Velocity (fpm)	Volume (cfm)	Uniformity (%)	Power Rating (watts)	
PH1036-1E**-PW	36	36	26	17	1/2	65	3950	1947	1460	91	460	
PH1042-1E**-PW	42	42	26	17	1/2	70	4150	1806	1580	89	500	
PH1048-1E**-PW	48	48	26	17	1/2	75	3895	1632	1632	91	520	
PH1060-2E**-PW	60	60	26	17	Two 1/2	115	3750	2217	2771	93	870	
PH1072-2E**-PW	72	72	26	17	Two 1/2	120	3950	1947	2920	91	920	
PH1084-2E**-PW	84	84	26	17	Two 1/2	140	4150	1806	3160	89	1000	
PH1096-2E**-PW	96	96	26	17	Two 1/2	145	3895	1632	3264	91	1040	
PH10108-3E**-PW	108	108	26	17	Three 1/2	195	3950	1947	4380	91	1380	
PH10120-4E**-PW	120	120	26	17	Four 1/2	230	3750	2217	5541	93	1730	
PH10144-4E**-PW	144	144	26	17	Four 1/2	260	3950	1947	5840	91	1840	

* - Use corresponding letters in "Voltage Code" & Wattage Code" to complete the model numbers.

Note: Data above for 1725 RPM at 60 Hz, 50 Hz is 1425 RPM with a 17% reduction in the performance data.

Features:

Air Curtain

- ❖ 1/2 HP Continuous Duty TEAO Motors
- ❖ Recessed mounted in ceiling for invisible coverage
- ❖ ETL Certified to conform to UL 2021 (US) and CSA 22.2 (Canada) Standards
- ❖ (4) 3/8" top mounting holes provided
- ❖ Utilized in premium design concepts
- ❖ Durable aluminum construction
- ❖ Cabinet has sufficient strength for fastening to wall on both ends without intermediate support. (Tandem mounted units longer than 72" require center support)
- ❖ Cleanable polyester filters included as standard
- ❖ Adjustable air directional vanes with 40° sweep front to back
- ❖ Standard color is Pearl White
- ❖ Rust preventative electrostatic polyurethane powder coating
- ❖ 18 month parts warranty
- ❖ Freight Included (FOB Continental USA)
- ❖ Proudly Made in the USA

Electric Heater Coil and Wiring

- ❖ Coils are an open type for rapid temperature rise to be located in the air curtain's intake directly in the air stream
- ❖ Manual reset thermal overload protection provided
- ❖ Controls internally mounted, prewired ready for power connection and accessible through the bottom intake or top access panels
- ❖ Control voltage is 24 volts
- ❖ A wall mounted 24 volt thermostat is included (field wired and installed by others)

Options and Accessories: (see Accessories Brochure)

- ❖ Remote mounted control panel
- ❖ Adjustable time delay (1 sec to 17 min)
- ❖ Remote mounted fused or non-fused disconnects
- ❖ Hi-Lo Heat
- ❖ Heat on Demand
- ❖ Master + Slave Control Kit
- ❖ 2 speed controls
- ❖ 1/4" and 1" Aluminum Mesh Filters
- ❖ Custom colors and finishes (304SS, 316SS)

Sound Levels: (measured at 10' in an open field)

1 Motor Unit = 66 dBA, 2 Motor Unit = 68 dBA, 3 Motor Unit = 71 dBA & 4 Motor Unit = 73 dBA

Three Phase Electrical Data (FLA)	Unit Voltage (Voltage Code) Amperage				Heater kilowatts (Wattage Code) kW			Temp Rise °F
	208v/3Ø (E)	230v/3Ø (F)	460v/3Ø (H)	575v/3Ø (I)	(H)	(N)	(S)	
PH1036-1E**-PW	36.0	33.0	16.0	13.0	12	-	-	27
PH1042-1E**-PW	36.0	33.0	16.0	13.0	12	-	-	27
PH1048-1E**-PW	36.0	33.0	16.0	13.0	12	-	-	26
PH1060-2E**-PW	72.0	66.0	32.0	26.0	-	24	-	28
PH1072-2E**-PW	72.0	66.0	32.0	26.0	-	24	-	27
PH1084-2E**-PW	72.0	66.0	32.0	26.0	-	24	-	27
PH1096-2E**-PW	72.0	66.0	32.0	26.0	-	24	-	26
PH10108-3E**-PW	108.0	98.0	48.0	39.0	-	-	36	27
PH10120-4E**-PW	110.0	101.0	49.0	39.0	-	-	36	26
PH10144-4E**-PW	110.0	101.0	49.0	39.0	-	-	36	26

* - Use corresponding letters in "Voltage Code and Wattage Code" to complete the model numbers.

For Ampacity Multiply FLA X 1.25

Motor amps per motor: 5.1A @ 115v; 2.5A @ 208/230v/1Ø; 0.8A @ 460v/3Ø; 0.7A @ 575v/3Ø.

Single Phase Electrical Data (FLA)	Unit Voltage (Voltage Code) Amperage		Heater kilowatts (Wattage Code) kW			Temp Rise °F
	208v/1Ø (B)	230v/1Ø (C)	(B)	(H)	(K)	
PH1036-1E**-PW	32.0	29.0	6	-	-	14
PH1042-1E**-PW	32.0	29.0	6	-	-	13
PH1048-1E**-PW	32.0	29.0	6	-	-	13
PH1060-2E**-PW	63.0	58.0	-	12	-	14
PH1072-2E**-PW	63.0	58.0	-	12	-	14
PH1084-2E**-PW	63.0	58.0	-	12	-	13
PH1096-2E**-PW	63.0	58.0	-	12	-	13
PH10108-3E**-PW	95.0	86.0	-	-	18	14
PH10120-4E**-PW	97.0	89.0	-	-	18	13
PH10144-4E**-PW	97.0	89.0	-	-	18	13

EXAMPLE

PH10 72 - 2 E H N -PW

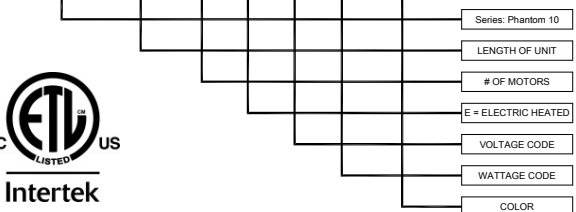

NOTE: MARS AIR SYSTEMS, LLC reserves the right to change specifications and product design without notice. Such revisions do not entitle the buyer to corresponding changes, improvements, additions or replacements for previously purchased equipment.