

Motor Control Panel

All Unheated and Hot Water and Steam Series

Model Voltage of 115V to 575V



atmosphere is everything

14716 S. BROADWAY, GARDENA, CA 90248 • Ph: (310) 532-1555 Fax: (310) 532-3030 • www.marsair.com
© Copyright Mars Air Systems, LLC 2014

Motor Control Panel Data Sheet

Motor Control Panel	Description	Panel Width A (in)	Panel Height B (in)	Panel Depth C (in)	Min Panel Door Clearance D (in)	Standard NEMA Rating
MCP*-1**	One Motor Control Panel	10	10	6	10	NEMA 1
MCP*-2**	Two Motor Control Panel	10	10	6	10	NEMA 1
MCP*-3**	Three Motor Control Panel	12	12	6	12	NEMA 1
MCP*-4**	Four Motor Control Panel	12	12	6	12	NEMA 1
MCP*-5**	Five Motor Control Panel	Contact Factory	Contact Factory	Contact Factory	Contact Factory	NEMA 1
MCP*-6**	Six Motor Control Panel	Contact Factory	Contact Factory	Contact Factory	Contact Factory	NEMA 1

* - Use corresponding letters for HP codes, Type of Heat then Voltage Code. Note: Panel dims shown are estimates and based on standard configurations. Sizes may change based on availability and optional accessories selected.

Features:

- ❖ Specifically designed to be used for the Mars Air Curtains
- ❖ ETL Certified to conform to UL 508A and CSA 22.2
- ❖ Enclosures are rated for NEMA 1 applications
- ❖ Panel constructed of a gray painted heavy gauge steel, hinged with a quarter turn latch (Polycarbonate enclosure may be used as a substitute)
- ❖ Hands-Off-Automatic (HOA) standard and mounted on the door
- ❖ Unit rated motor contactors and overloads/motor protectors
- ❖ Step-down transformer used for the 120V secondary control (50-75VA) Hot Water and Steam units utilize a larger transformer(250VA) in order to power the solenoid valve
- ❖ Control fuses and equipment grounding
- ❖ Terminal strips for input power and motor connections provided
- ❖ 1 year parts warranty
- ❖ Following unheated and HW/S heated models will not include overloads and motor protectors (the motors are internally thermally protected)
 - (1/2 HP) STD2, N2 series
 - (1 HP) HV2, NH2 series
 - (3 HP) EP2 series

HP	Code
1/2	A
1	B
2	C
3	D
5	E
7	F
7 1/2	G
10	H
15	I
20	J
25	K
30	L
40	M
1 & 3	P
*Special	S

Options and Accessories: (see Accessories Brochure)

- ❖ NEMA 4X or NEMA 7 or 9 enclosure with HOA
- ❖ Custom enclosure colors and finishes (304SS, 316SS, Aluminum)
- ❖ Non-fused and Fused Disconnects (Specify remote or panel mounted)
- ❖ Adjustable Time Delay (1 sec to 17 min) (Specify alternate delay length)
- ❖ 2 or 3 speed control (Not available for all models) (Specify remote or panel mounted)
- ❖ Keyed quarter turn latch
- ❖ Keyed HOA switch (Panel mounted)
- ❖ Factory mounted panels (Specify panel location)
- ❖ Special voltages and 50 Hz available (Contact factory)
- ❖ Special control voltage (24V) available (Contact factory)

Heating	Code
Unheated	U
Hot Water or Steam	V

Voltage	Code
115-1-60	A
208/230-1-60	D
208/230-3-60	G
460-3-60	H
575-3-60	I

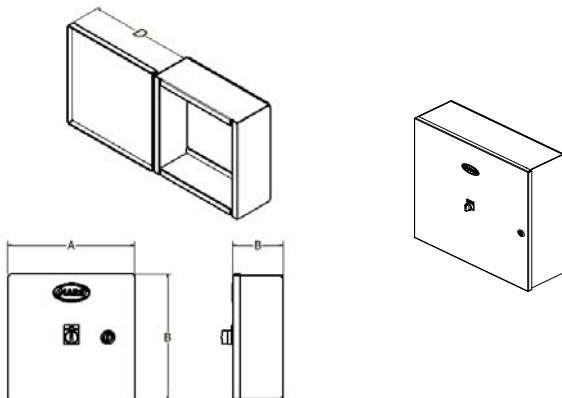

EXAMPLE

MCP A -1 U H -TD

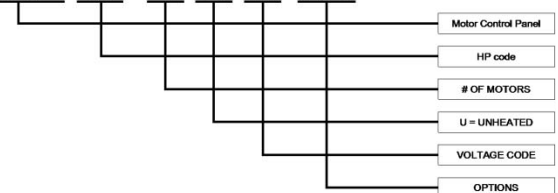

NOTE: MARS AIR SYSTEMS, LLC reserves the right to change specifications and product design without notice. Such revisions do not entitle the buyer to corresponding changes, improvements, additions or replacements for previously purchased equipment.