

# Harsh Weather Covers

All Unheated Models

Model Lengths 25" – 192"



atmosphere is everything

14716 S. BROADWAY, GARDENA, CA 90248 • Ph: (310)532-1555 Fax: (310)-532-3030 • [www.marsair.com](http://www.marsair.com)  
© Copyright Mars Air Systems, LLC 2014

## Harsh Weather Covers for Unheated Models

Harsh Weather Cover Model #	Air Curtain Series	Air Curtain Length (in)	Width A (in)	Projection B (in)	Drop C (in)	Valance D (in)	Replacement Fabric Part #
40-101GRY	LPV2/STD2	25 & 36	42	28	20	6	40-001-GRY
40-102GRY	LPV2/STD2	42 & 48	54	28	20	6	40-002-GRY
40-103GRY	LPV2/STD2	60, 64 & 72	78	28	20	6	40-003-GRY
40-104GRY	LPV2/STD2	78, 84 & 96	102	28	20	6	40-004-GRY
40-105GRY	LPV2/STD2	108, 120 & 144	150	28	20	6	40-005-GRY
40-121GRY	HV2/EP2	36	46	32	24	8	40-021-GRY
40-122GRY	HV2/EP2	42 & 48	58	32	24	8	40-022-GRY
40-123GRY	HV2/EP2	60 & 72	82	32	24	8	40-023-GRY
40-124GRY	HV2/EP2	84 & 96	106	32	24	8	40-024-GRY
40-125GRY	HV2/EP2	108, 120 & 144	154	32	24	8	40-025-GRY
40-140GRY	WM/BD	72	96	66	46	22	40-040-GRY
40-141GRY	WM/BD	84	108	66	46	22	40-041-GRY
40-142GRY	WM/BD	96	120	66	46	22	40-042-GRY
40-143GRY	WM/BD	108	132	66	46	22	40-043-GRY
40-144GRY	WM/BD	120	144	66	46	22	40-044-GRY
40-145GRY	WM/BD	144	168	66	46	22	40-045-GRY
40-146GRY	WM/BD	168	192	66	46	22	40-046-GRY
40-147GRY	WM/BD	180	204	66	46	22	40-047-GRY
40-148GRY	WM/BD	192	216	66	46	22	40-048-GRY
40-149GRY	WM/BD	216	240	66	46	22	40-049-GRY

**Note: Harsh Weather Covers are not for use with heated models.**

### Features:

- ❖ Heavy duty welded 1" x 1" 16 gauge painted galvanized steel
- ❖ Heavy duty weather proof fabric by SunBrellap®
- ❖ Helps absorb noise transmitted from air curtain
- ❖ Protects the entry doorway from sun or rain damage
- ❖ Able to withstand winds up to 80 mph
- ❖ Protects air curtain from outdoor elements
- ❖ Z clips and mounting hardware included for easy installation
- ❖ Standard fabric color is Slated Grey
- ❖ Lightweight construction for easy shipping
- ❖ Shipped fully assembled
- ❖ 1 year warranty
- ❖ Freight not included
- ❖ Proudly Made in the USA

### Options and Accessories: (see Accessories Brochure)

- ❖ Custom colors available (Navy Blue and Mars Red)
- ❖ Custom chrome powder coated and brass mill finish frames available

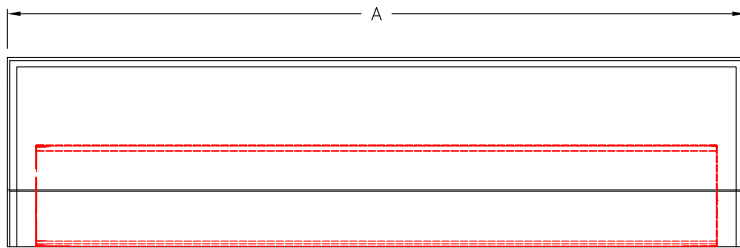
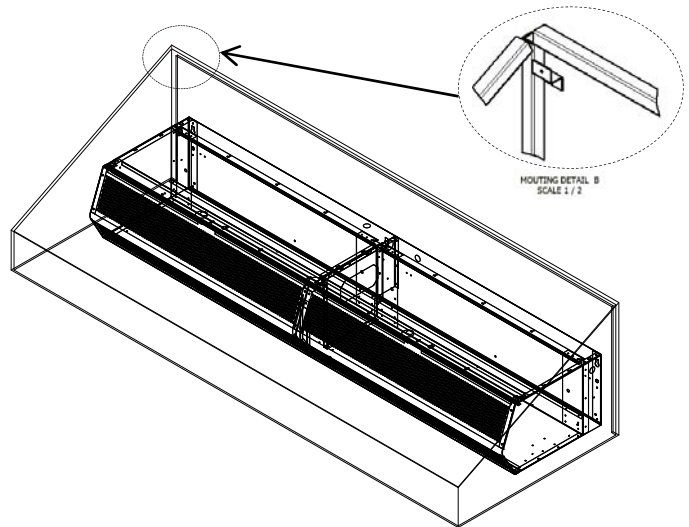

FRONT VIEW

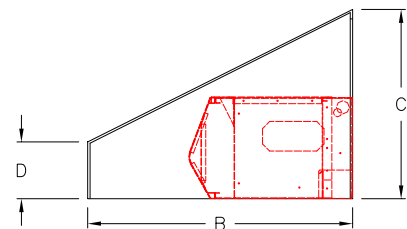

SIDE VIEW

NOTE: MARS AIR SYSTEMS, LLC reserves the right to change specifications and product design without notice. Such revisions do not entitle the buyer to corresponding changes, improvements, additions or replacements for previously purchased equipment.