



atmosphere is everything

14716 S. Broadway • Gardena, CA 90248 • USA
 TEL: (310) 532-1555 • (800) 421-1266 • FAX: (310) 324-3030
 Web Site: www.marsair.com • E-mail: info@marsair.com

PROJECT		OPTIONS/ITEMS	
TITLE		DATE	
COMMENTS		4/25/16	PAGE
		REV. NO	
MODEL NO. HV2 Series	DRAWING NO HV2I-F	DRAWN BY BH	CHECKED BY
		FILE NAME	

Indirect Fired Gas Heated Drawing

HV2 (High Velocity 2) Series

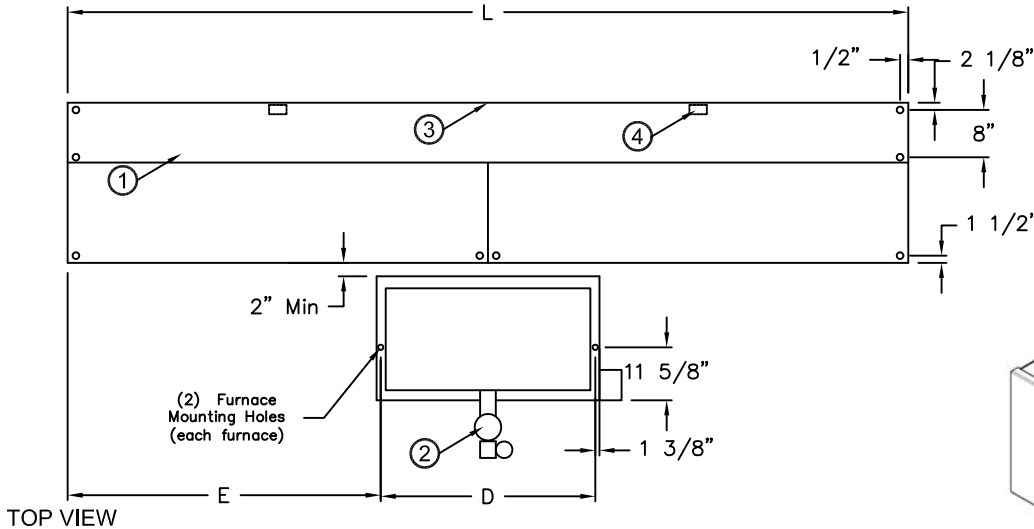

TOP VIEW

7 Recommended Accessories

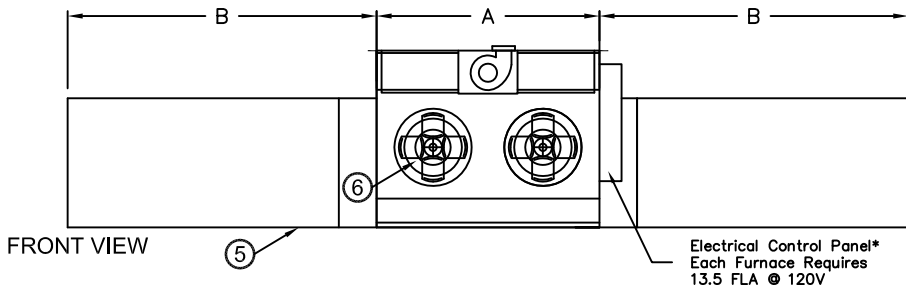
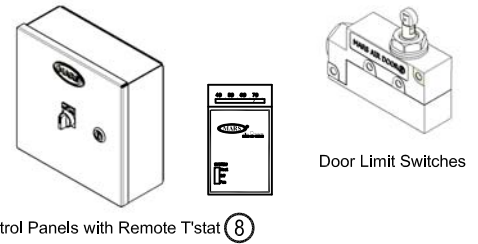

FRONT VIEW

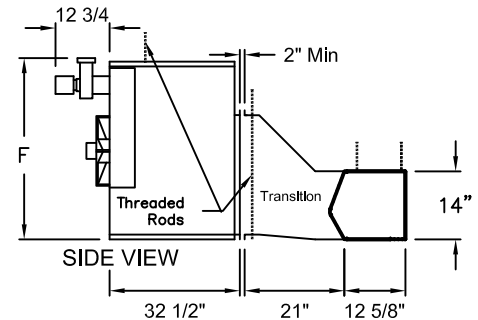

SIDE VIEW

Notes:

- The Air Curtains are ETL Listed for the US and Canada with 7/16" mounting holes for overhead mounting.
- The Furnaces are ETL verified to be 83% efficient with 3/8" overhead mounting hardware for overhead mounting.
- Cabinet has sufficient strength for fastening from overhead on both ends without intermediate support. Furnace must be mounted at least 2" away from the transition. Transition pieces are provided with pilot holes for easy field assembly and hardware is included. Units larger than 8' utilize multiple transitions.
- Internal J-Box(es) for electrical wiring: one motor-(1) 2"x 4"; two motors-(1) 4"x 4"; three motors-(2) 4"x 4".
- Unit is to be installed such that air flow is unobstructed. Air discharge nozzle containing adjustable air directional vanes with 40° sweep front to back.
- Furnaces with impellers have positive pressure, 20 gauge aluminized tubular heat exchanger with in-shot burner technology, power vented exhaust (horizontal or vertical), single stage gas valve, direct spark ignition and certified for Category I and III venting.
- Circuit protection as per NEC by others.
- Optional motor control panel, door limit switch and mounting brackets are field installed and/or wired by others. The door limit switch is to be mounted such that the air curtain turns on as door begins to open. To prevent unit damage, the mounting brackets must be installed such that the bottom of the air curtain is not below the door header.

Note: MARS reserves the right to change specifications and product design without notice. Such revisions do not entitle the buyer to corresponding changes, improvements additions or replacements for previously purchased equipment.

*- Use corresponding letters in "Electrical Data" columns to complete the model numbers.

MODEL NUMBER	Overall Width (In) L	Furnace Width (In) A	End Space (In) B	Mounting Distance (In) D	End Dim (In) E	Furnace Height (In) F	Furnace Size (MBH)
HV296-2I*-TS	96	32 3/4	31 5/8	30 5/8	33	33 3/4	250
HV2108-3I*-TS	108	50 3/4	28 5/8	48 5/8	30	34	300
HV2120-2I*-TS	120	50 3/4	34 5/8	48 5/8	36	34	300
HV2120-3I*-TS	120	50 3/4	34 5/8	48 5/8	36	34	350
HV2144-3I*-TS	144	50 3/4	46 5/8	48 5/8	48	34	400

HV2 (High Velocity 2) Series

Indirect Fired Gas Heated
Model Lengths 96" – 144"



atmosphere is everything

14716 S. BROADWAY, GARDENA, CA 90248 • Ph: (310) 532-1555 Fax: (310) 532-3030 • www.marsair.com
© Copyright Mars Air Systems, LLC 2014

Indirect Fired Gas Heated Data Sheet

Applications: Environmental Separation (up to 12')

HV2 (High Velocity) Series 2	Mechanical Data							Lab Data					
	Model Number	Nozzle Length (in)	Length (in)	Min. Depth (in)	Height (in)	Motor (hp)	Total Weight*** (lbs)	Furnace Weight (lbs)	Max Core Velocity at Nozzle (fpm)	Max Volume (cfm)	Avg Velocity (fpm)	Volume (cfm)	Uniformity (%)
HV296-2I'-TS	96	96	67 1/2	33	Two 1	551	211	6144	8000	2447	4894	88	2720
HV2108-3I'-TS	108	108	67 1/2	33	Three 1	733	307	5722	12000	2389	5376	92	2895
HV2120-2I'-TS	120	120	67 1/2	33	Two 1	683	307	6330	8000	2208	5519	80	3120
HV2120-3I'-TS	120	120	67 1/2	33	Three 1	767	321	6060	12000	2678	6693	93	3615
HV2144-3I'-TS	144	144	67 1/2	33	Three 1	822	335	6144	12000	2447	7341	88	4080

* - Use corresponding letters in "Electrical Data" columns to complete the model numbers.

*** - Total Weight includes air curtain, transition and furnace

Note: Data above for 1725 RPM at 60 Hz, 50 Hz is 1425 RPM with a 17% reduction in the performance data.

Features:

- Air Curtain and Transition
- 1 HP Continuous Duty Motors
- Air curtain is a self-contained one piece heavy gauge corrosion proof paint lock metal design*
- Air curtain is ETL Certified to conform to UL 507 (US) and CSA 22.2 (Canada) Standards
- Top mounting holes provided (7/16")
- Cabinet has sufficient strength for fastening from overhead on both ends without intermediate support
- Adjustable air directional vanes with 40° sweep front to back
- Transition is shipped KD (Knocked Down) to minimize freight and storage expenses
- Transition pieces are provided with pilot holes for easy field assembly (Hardware included)
- Standard color is Titanium Silver
- Rust preventative electrostatic polyurethane powder coating
- 12 month parts warranty
- Freight FOB the factory
- Proudly Made in the USA

*Note: Motor/Fan Assembly(s) (MFA) are shipped loose to minimize freight damage and installation costs.

Indirect Fired Gas Furnaces

- ETL verified to be 83% efficient
- In-shot burner technology
- Aluminized tubular heat exchanger (20 gauge)
- Positive pressure 120V impellers (separate 120V, 1Ø power req'd)
- Power vented exhaust
- Single stage gas valve
- Standard direct spark ignition
- Certified for Category I and III Venting
- Natural gas
- Factory test fired
- Overhead mounting hardware provided (2 per furnace)

Options and Accessories: (see Accessories Brochure)

- Motor Control Panels with remote mounted t'stat
- 409 and 321 stainless steel heat exchangers
- Separated combustion
- Two stage and modulating gas valves
- LP gas
- Custom housing and transition colors and finishes (304SS, 316SS)

Sound Levels: (measured at 10' in an open field)

2 Motor Unit = 73 dBA, 3 & 4 Motor Unit = 75 dBA

NOTE: MARS AIR SYSTEMS, LLC reserves the right to change specifications and product design without notice. Such revisions do not entitle the buyer to corresponding changes, improvements, additions or replacements for previously purchased equipment.

Electrical Data (FLA)	Unit Voltage (Voltage Code)			Electrical Data (FLA) Furnace
	208/230v (G)	460v (H)	575v (I)	
HV296-2I'-TS	6.6/6.4	3.2	2.6	8.0
HV2108-3I'-TS	9.9/9.6	4.8	3.9	11.3
HV2120-2I'-TS	6.6/6.4	3.2	2.6	11.3
HV2120-3I'-TS	9.9/9.6	4.8	3.9	13.5
HV2144-3I'-TS	9.9/9.6	4.8	3.9	13.5

* - Use corresponding letters in "Electrical Data" columns to complete the model numbers.

Note: For Ampacity Multiply FLA X 1.25

HV2 (High Velocity) Series 2	Indirect Fired Gas Data					
	Model Number	# of Furnaces	Input MBH per Furnace	Total Output MBH	Temp Rise (°F)	Flue Size
HV296-2I'-TS	1	250	207.5	39	5" Rnd	1/2"
HV2108-3I'-TS	1	300	249	43	6" Rnd	3/4"
HV2120-2I'-TS	1	300	249	42	6" Rnd	3/4"
HV2120-3I'-TS	1	350	290.5	40	6" Rnd	3/4"
HV2144-3I'-TS	1	400	332	42	6" Rnd	3/4"

EXAMPLE

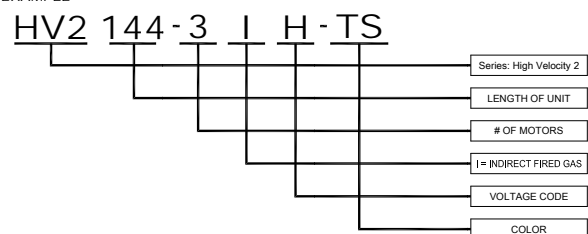

Air Curtain Only



Furnace Only