



atmosphere is everything

14716 S. Broadway • Gardena, CA 90248 • USA
 TEL: (310) 532-1555 • (800) 421-1266 • FAX: (310) 324-3030
 Web Site: www.marsair.com • E-mail: info@marsair.com

PROJECT		OPTIONS/ITEMS	
TITLE			
COMMENTS		DATE 4/17/15	PAGE
		REV. NO	
MODEL NO. BD30 Series	DRAWING NO. BD30E-F	DRAWN BY TVN	CHECKED BY
		FILE NAME	

Electric Heated Drawing

BD30 (Belt Driven 30) Series

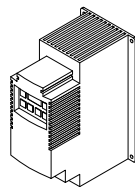
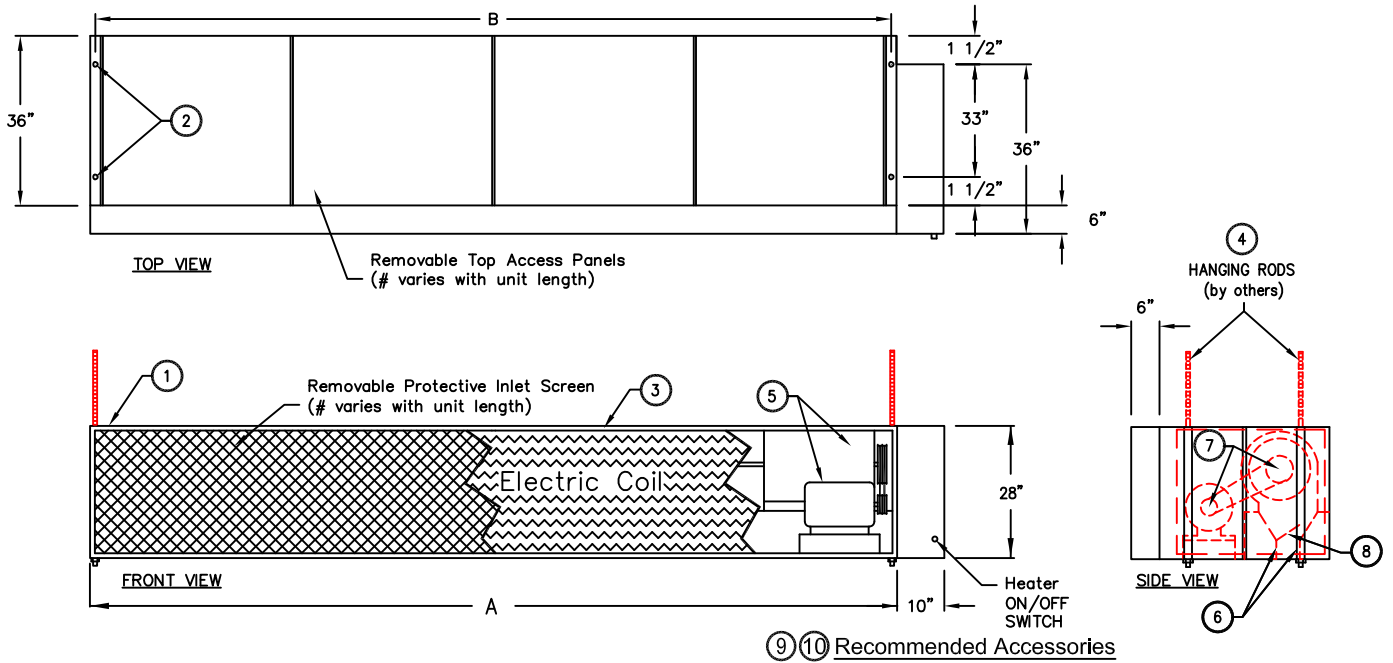

Variable Frequency Drive



Control Panels with Remote T'stat



Door Limit Switches

*- Use corresponding letters in "Electrical Data" columns to complete the model numbers.

MODEL NUMBER	NOZZLE LENGTH (in)	OVERALL LENGTH A (in)	MOUNTING WIDTH B (in)
BD3096-1E*-TS	96	107	105 1/2
BD30120-1E*-TS	120	131	129 1/2
BD30144-1E*-TS	144	155	153 1/2
BD30168-1E*-TS	168	179	177 1/2
BD30192-2E*-TS	192	203	201 1/2

Notes:

- This product is designed to meet the National Electric Code (NEC) and is CSA Listed.
- (4) 5/8" mounting holes provided on for overhead mounting provided, (2) on each end.
- All units have a self contained one piece cabinet, fire retardant and corrosion proof paint lock metal double protected with baked on Titanium Silver color, rust preventative electrostatic polyurethane powder coating.
- Cabinet is to be mounted from overhead and has sufficient strength for suspension from both ends without intermediate support.
- Unit is to be installed such that air flow is unobstructed. Unit has a 4.5" air discharge nozzle containing adjustable air directional vanes with 40° sweep front to back. To prevent unit damage, the air curtain must be installed such that the bottom of the air curtain is not below the door header.
- Units are direct drive. One external top mounted 2"x4" J-box provided above each motor.
- Electric heater shown with heater component panel on right side, as standard. (Note: This is not the same as the optional remote air curtain unit control panel, see note 10.) Optional left hand mounting available. Special remote mounted heater component panel available for installations with space limitations. Contact factory for details and minimum installation space requirements.
- Wall mounted 24 volt thermostat with remote "heat/off/fan" switch is shipped loose and field installed. Terminal block provided inside control panel.
- Circuit protection as per NEC by others.
- Optional remote air curtain unit control panel and door limit switch are field installed and wired by others. The remote air curtain unit control panel is required when a door limit switch is used to automatically turn the air curtain on as door begins to open. Special remote mounted heater component panel (see note 7) is integrated with the optional remote air curtain unit control panel when the two options are selected.

BD30 (Belt Drive) Series

Electric Heated

Model Lengths 96" – 192"



atmosphere is everything

14716 S. BROADWAY, GARDENA, CA 90248 • Ph: (310) 532-1555 Fax: (310) 532-3030 • www.marsair.com
© Copyright Mars Air Systems, LLC 2014

Electric Heated Data Sheet

Applications: Environmental Separation (up to 30')

BD30 (WindGuard)	Mechanical Data						Lab Data	
Model Number	Nozzle Length (in)	Length (in)	Depth (in)	Height (in)	Motor (hp)	Weight (lbs)	Max Velocity (fpm)	Max Volume (cfm)
BD3096-1E*-TS	96	107	42	28	20	950	6950	19200
BD30120-1E*-TS	120	131	42	28	25	1075	6950	24900
BD30144-1E*-TS	144	155	42	28	30	1200	6950	30300
BD30168-1E*-TS	168	179	42	28	30	1325	6950	33000
BD30192-2E*-TS	192	203	42	28	Two 20	1450	6950	38100

* - Use corresponding letters in "Electrical Data" columns to complete the model numbers.

Note: Data above is for 60 Hz, 17% reduction in the performance data with 50 Hz.

Features:

- Air Curtain
- ❖ 20 to 30 HP Heavy Duty TEFC Motors
- ❖ Air curtain has a self-contained cabinet with sufficient strength for fastening from overhead on both ends without intermediate support. Top and rear mounting holes provided (4) 3/4"
- ❖ Adjustable air directional nozzle with 40° sweep front to back
- ❖ Standard color is Titanium Silver
- ❖ Rust preventative electrostatic polyurethane powder coating
- ❖ All units are shipped fully assembled ready for installation
- ❖ 18 months parts warranty
- ❖ Freight Not Included (FOB Factory)
- ❖ Proudly Made in the USA

Electric Heater Coil and Wiring

- ❖ Coils are an open type for rapid temperature rise to be located in the air curtain's intake directly in the air stream.
- ❖ Manual reset thermal overload protection provided
- ❖ Controls are externally mounted, prewired ready for power connection
- ❖ A heat ON/OFF switch is unit mounted on external controls

Options and Accessories: (see Accessories Brochure)

- ❖ Remote air curtain unit control panel with remote mounted t'stat
- ❖ Remote electric heater component panel
- ❖ Custom housing and transition colors and finishes (304SS, 316SS, Aluminum)

Sound Levels: (measured at 10' in an open field)

15 HP Motor Unit = 76 dBA, 20 HP Motor Unit = 77 dBA, 25 HP Motor Unit = 78 dBA, 30 HP Motor Unit = 79 dBA, (2) 20 HP Motor Unit = 80 dBA

Electrical Data (FLA)	Unit Voltage (Voltage Code) Amperage			Heater Data	
	208v (E)	460v (H)	575v (I)	3Ø kW	Temp Rise (°F)
BD3096-1E*-TS	506	229	183	182	30
BD30120-1E*-TS	656	297	237	236	30
BD30144-1E*-TS	800	362	290	288	30
BD30168-1E*-TS	869	393	315	313	30
BD30192-2E*-TS	1005	455	364	362	30

* - Use corresponding letters in "Electrical Data" columns to complete the model numbers.

Note: For Ampacity Multiply FLA X 1.25

Model Number	Motor Amperage		
	208-230v/3Ø (G)	460v/3Ø (H)	575v/3Ø (I)
BD3096-1E*-TS	55.0/51.0	25.5	20.2
BD30120-1E*-TS	65.0/60	30.0	24.8
BD30144-1E*-TS	78.0/71.0	35.5	29.7
BD30168-1E*-TS	78.0/71.0	35.5	29.7
BD30192-2E*-TS	110.0/102.0	51.0	40.4

* - Use corresponding letters in "Electrical Data" columns to complete the model numbers.

Note: For Ampacity Multiply FLA X 1.25

EXAMPLE

BD30168-1 E H - TS

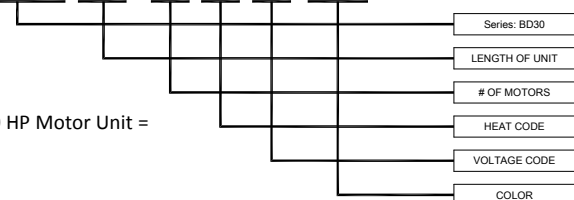

NOTE: MARS AIR SYSTEMS, LLC reserves the right to change specifications and product design without notice. Such revisions do not entitle the buyer to corresponding changes, improvements, additions or replacements for previously purchased equipment.